

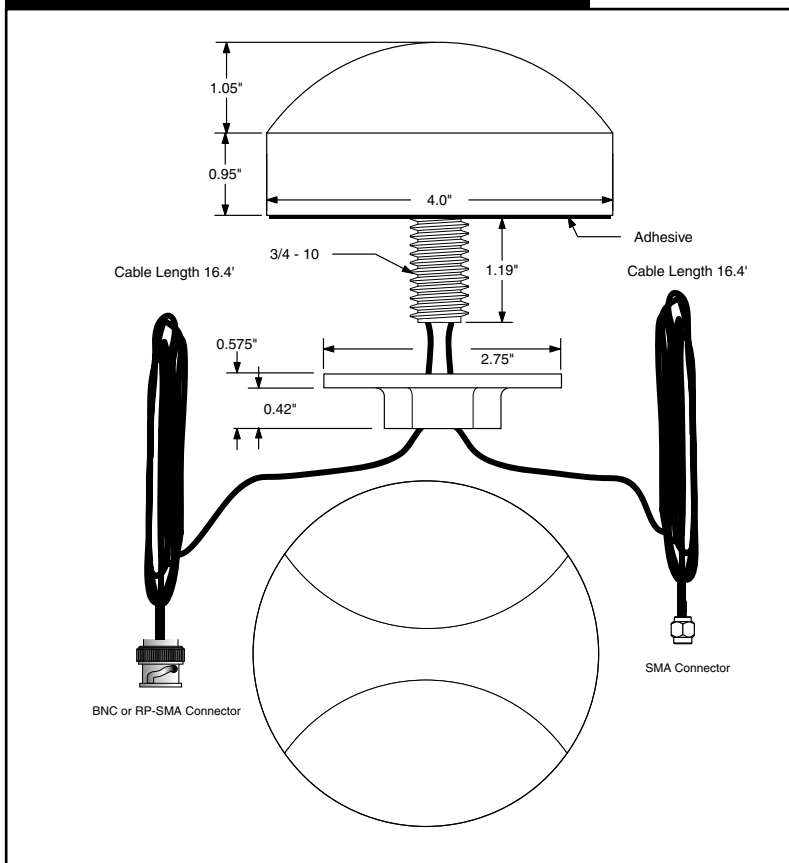

A breakthrough in dual-band antenna technology, the CELNSAT antenna combines a wide-band ISM or Cell-band antenna with a high-efficiency, amplified GPS antenna. Housed in a weather-tight, tamper-resistant dome, the CELNSAT is ideal for mounting on devices such as vehicles, vending machines, or equipment housings.

- Unique dual-band configuration.
- High-efficiency amplified GPS antenna.
- High-performance broadband Cell or ISM element.
- Low-profile weatherproof housing.
- Both elements matched to 50Ω.
- Center-fed through rugged mounting stud.
- Ideal for mobile or stationary applications.
- Color and terminations customizable for volume OEMs.

### PHYSICAL DIMENSIONS



### ELECTRICAL SPECIFICATIONS

SPECIFICATION	GPS	859MHZ	915MHZ
Frequency	1575.42MHz	824-894	902-928
Gain	5dBi	2dBi	2dBi
V.S.W.R.	<2.0	<1.7	<1.7
Impedance	50Ω	50Ω	50Ω
Polarization	RHCP	Vertical	Vertical
Pattern	Hemispherical	Omnidirectional	Omnidirectional
GPS LNA:			
Gain:	32± 2dB		
Noise Figure:	2.0dB (max)		
Voltage:	5VDC (±10%)		
Current:	20mA (max)		

### MECHANICAL SPECIFICATIONS

SPECIFICATION	GPS	859MHz (CELL)	916MHz (ISM)
Connector	SMA (Male)	BNC	RP-SMA (Female)
Cable	1.5D-2V 16.4 ft. ± 2 in.		
Case	ABS		
Color	White		
Mounting	Threaded stud (20mm hole)		
Weight (Max)	2.6 lb. (with cable assy.)		

### ORDERING INFORMATION

PART #	DESCRIPTION
ANT-916-DBD-DA/W	Dual Band Antenna (ISM)
ANT-859-DBD-DA/W	Dual Band Antenna (CELL)